



# Quilted Carry All (P-016)

Toll-Free: 1-800-361-4120 • 514-382-2400  
 info@camelotfabrics.com • camelotfabrics.com

Designer by Camelot Design Studio for Camelot Fabrics



HARRY POTTER characters, names and related indicia are © & ™ Warner Bros. Entertainment Inc. Publishing Rights © J.K.R. (s18)

- Skill Level: ●●●●●
- Final Size (excluding strap): 12"D x 16"H

### Fabric Requirements



- Fabric A - 2/3 yds of Harry Potter quilting cotton (44" wide) from Camelot Fabrics in 23800139 01
- Fabric B - 5/8 yds of Harry Potter quilting cotton (44" wide) from Camelot Fabrics in 23800137 02
- Lining - 1 yd of quilting cotton in 214-0043 Rainwater

## OTHER TOOLS & SUPPLIES

- Sewing machine
- Needle & coordinating thread
- Iron and pressing surface
- Rotary cutter and mat
- Straight pins
- Ruler
- Scissors
- Batting 1-1/8 yd of 58" wide batting
- Pencil
- Large safety pin

## NOTES

1. Please wash, dry & iron your fabrics before beginning, and trim selvages.
  2. For best results, read all directions before beginning.
  3. Unless otherwise noted, use a 1/2" seam allowance (SA)
  4. Unless otherwise noted, press all seams open.
- WOF = Width of Fabric

## CUTTING

Cut out the template pieces (pp. 10-13) for the bottom of the bag. Tape the pages together, making sure to match up the numbered squares.

### Fabric A

Cut (1) 11" x WOF strip  
Sub-cut (2) 20" x 11" rectangles

Cut (2) 2-1/2" x WOF strips  
Sub-cut *each* strip to (1) 22-1/2" x 2-1/2" strip (set aside for handles)

Cut (3) 2" x WOF strips. Sew strips together end to end and sub-cut to (2) 45" x 2" strips (set aside for drawstrings)

### Fabric B

Cut (1) 7" x WOF strip  
Sub-cut (2) 20" x 7" rectangles

From Remaining Fabric B:

Cut (1) 14" strip along the *length* of the fabric  
(parallel to the selvage)  
Sub-cut to (1) 14" x 14" square

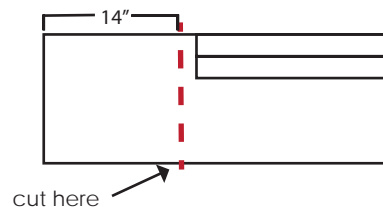

From remaining piece, cut (2) 2-1/2" strips  
Sub-cut *each* strip to (1) 22-1/2" x 2-1/2" (set aside for handles)



## Fabric C

Cut (1) 17" x WOF strip  
Sub-cut (2) 20" x 17" rectangles

Cut (1) 14" x WOF strip  
Sub-cut (1) 14" x 14" square

## Batting

Cut (2) 24" x 21" rectangles (for body of bag)

Cut (1) 16" x 16" squares (for bottom of bag)  
Cut (2) 2" x 22" rectangles (for handles)

## ASSEMBLY

1. Sew (1) 20" x 11" Fabric A rectangle to (1) 20" x 7" Fabric B rectangle, as shown. Repeat to make 2.

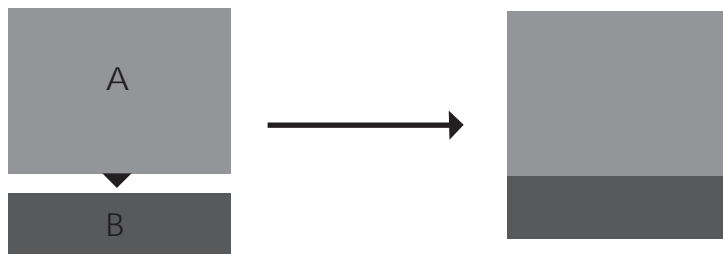

2. Layer (1) piece created in Step 1 on a 24" x 21" rectangle of batting. Pin or baste and quilt as desired. To quilt it as in the example below, begin by quilting diagonal lines spaced 2" apart in one direction. Then quilt diagonal lines perpendicular to those to create the crosshatch. Stitch around the perimeter of the quilted piece about 1/8" from the edge. Trim off the excess batting.

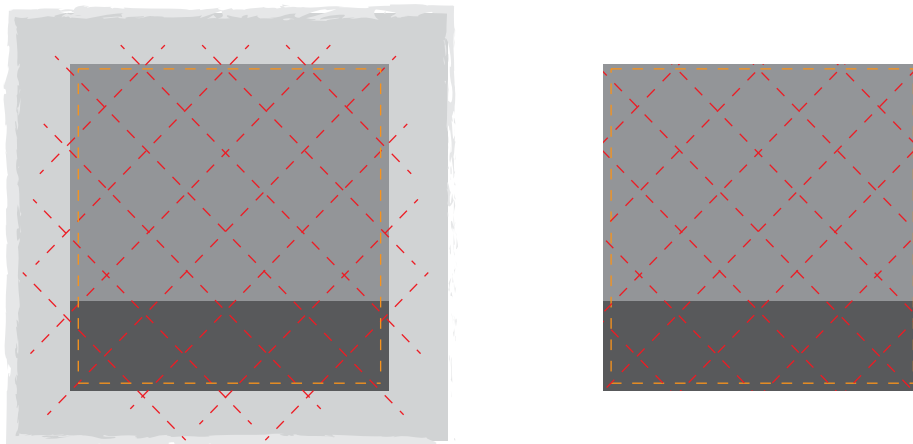

3. Repeat Step 2 to quilt and trim the second rectangle from Step 1.

4. Layer the 14" Fabric B square and the 16" square piece of batting. Quilt as you did with the pieces from Step 2.
5. Use the circle template to trace a circle on the quilted square. Stitch around the circumference of the circle about 1/8" *inside* the drawn line. Trim on the drawn line.

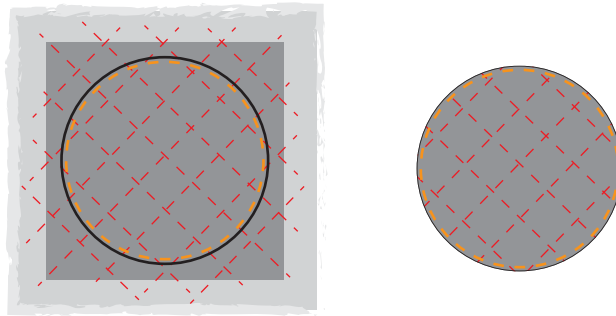

6. Trace the circle template onto the wrong side of 14" Fabric C square. Cut on the drawn line.
7. Take the two pieces created in Steps 2 & 3 and place one over the other, Right Sides Facing, making sure that the seams are lined up.

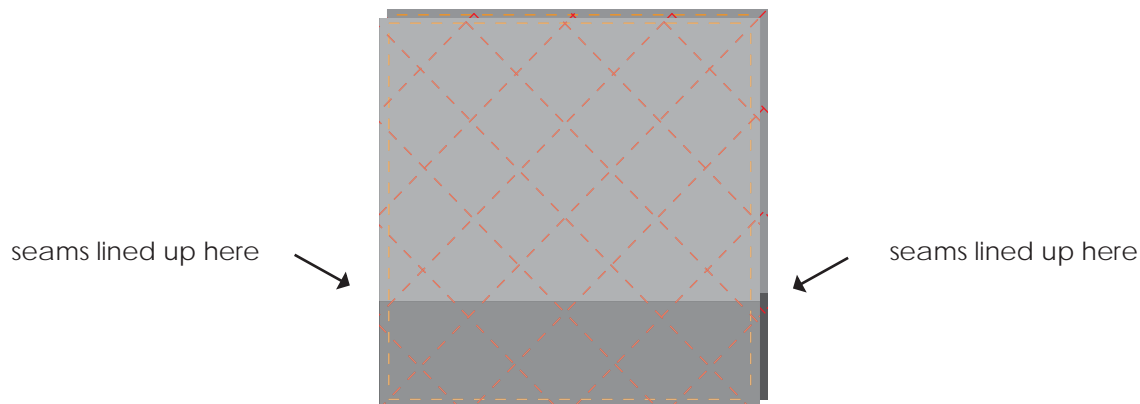

8. Sew a seam along the two sides, making sure to backstitch at the beginning and end of each stitch. Press seams open.

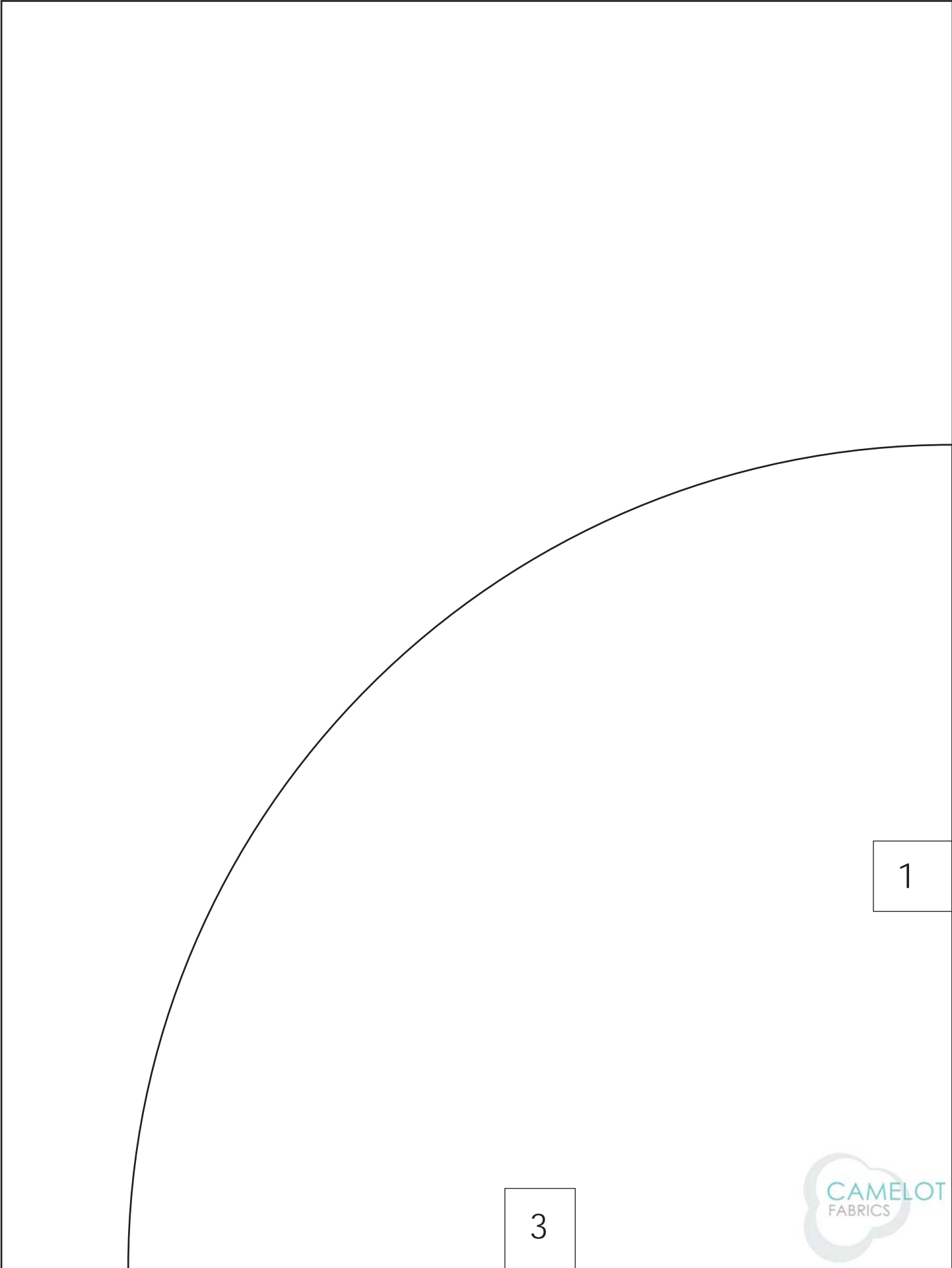

1

3



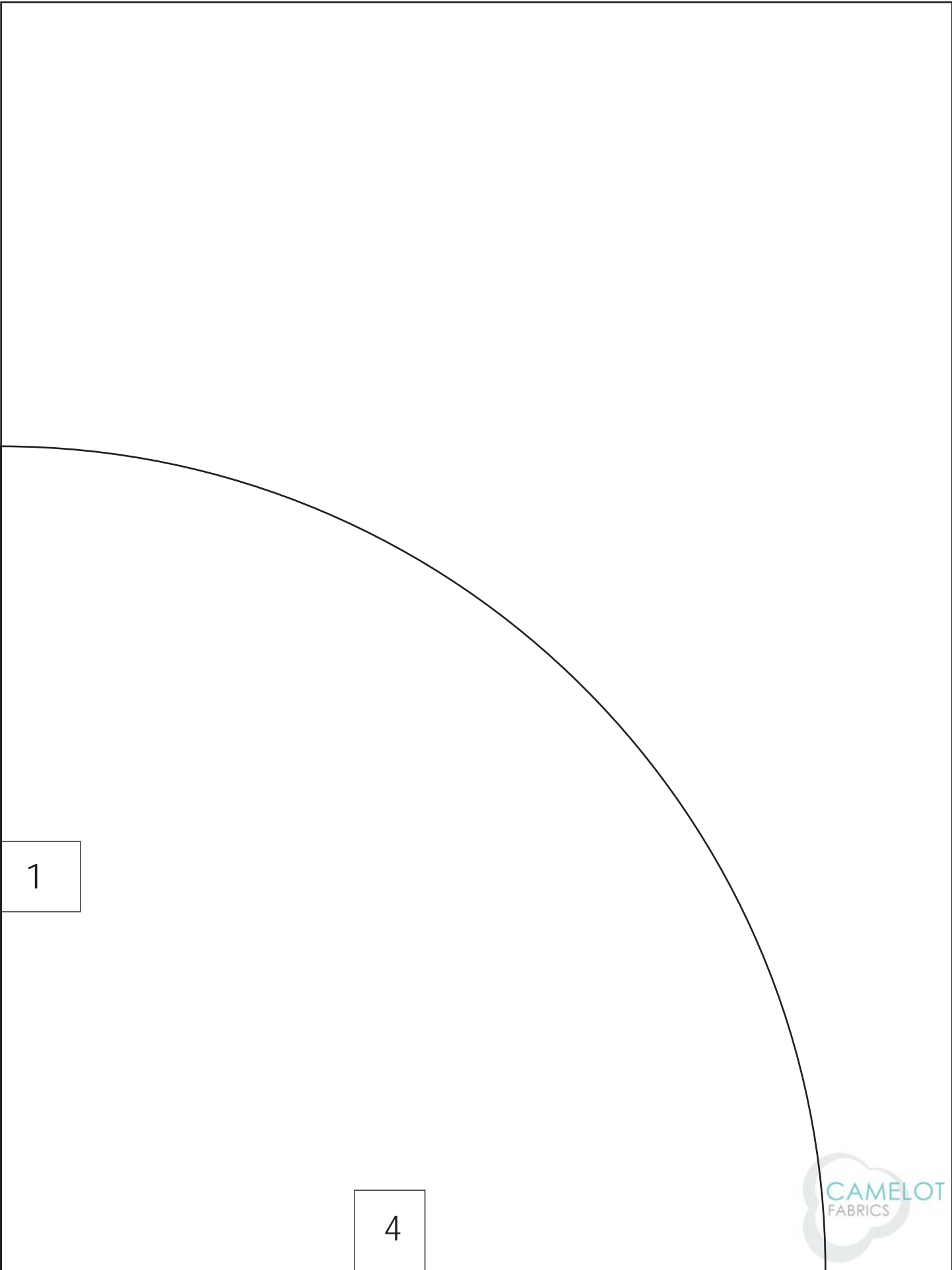

3

2



4

2





9. Take the two Fabric C rectangles and place one over the other, Right Sides Facing. Sew a seam along the two sides, making sure to backstitch at the beginning and end of each stitch. Press seams open.

NOTE: Leave a six inch opening on one side. You'll need to turn your work Right Side Out through this gap once you've sewn all the parts together.

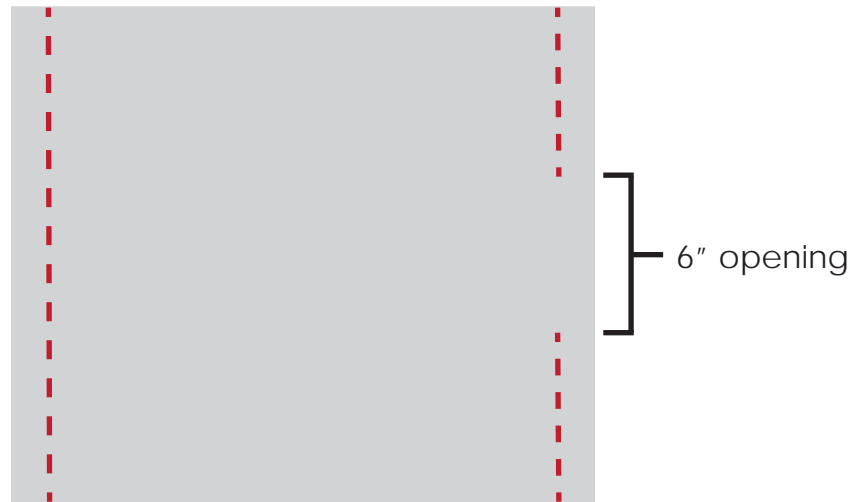

You now have two 'tubes', one quilted & one not. Leave the tubes inside out.

10. Pin & sew the quilted circle to the bottom end of the quilted Tube, Right Sides together.

Begin by folding the circle piece in half & again into quarters. Finger press to mark the creases. Insert a pin at each crease mark. Fold again to divide the circle into eighths by finding the center point between two pins. Insert a pin at each new crease mark.

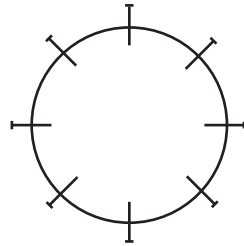

Next, flatten the tube to mark the two halves, open & flatten again to make the quarter marks. Insert a pin at each crease mark. Fold again to divide into eighths by finding the center point between two pins. Insert a pin at each new crease mark.

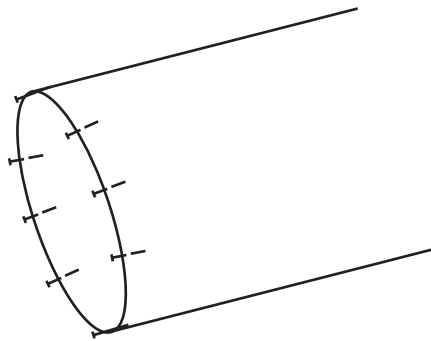

11. Line up the marks on the tube with the marks on the circle and pin, Right Sides Facing. Continue to add pins between the marks until the fabrics lay flat against each other.

See box below for tips on successful pinning.

**Tips for pinning curves:**

Begin by finding the center mark between two pins & distribute the 'excess' fabric evenly between the 2 halves. Place a pin on the center mark. Continue to pin in this manner until the two fabrics lay flat against each other. Don't be afraid to use lots of pins!

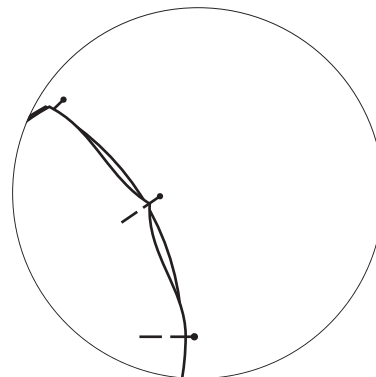

12. Sew the two pieces together, removing pins as you go. NOTE: It is easier to sew with circular piece at the bottom. Be sure to backstitch at the beginning and end to lock in your stitches. this creates the outer layer of the bag. Leave inside out.

13. Repeat Steps 10-12 with the Fabric C tube and circle pieces to create the bag lining. Turn right side out.

14. Divide the top opening of each bag piece into eighths (Following the instructions from Step 10) and mark with a pin.

15. Insert the lining into the outer bag. Line up the side seams and the pin marks of both pieces and pin. Continue to add pins all around, following the 'Tips for pinning curves' on page 5.

16. Sew around the top opening of the bag, removing pins as you go. Be sure to backstitch at the beginning and end to lock in your stitches.

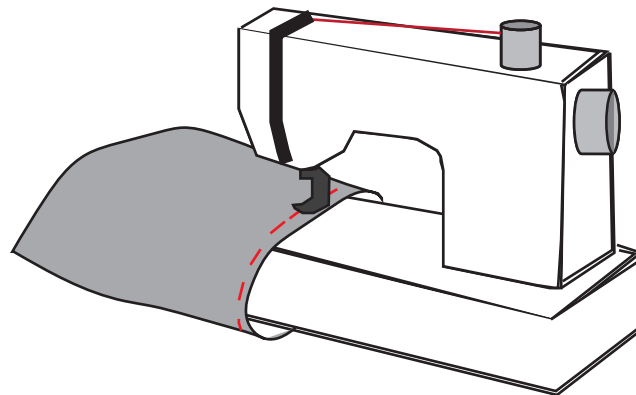

17. Pull the lining out of the outer bag. Turn your work right side out through the opening in the lining. Push the lining back into the outer bag. Press along the top seam to flatten it.

18. Top stitch along the top close to the edge (about 1/8").

19. Topstitch around the bag again, this time 1" from the top edge. This will create the channel for the drawstring.

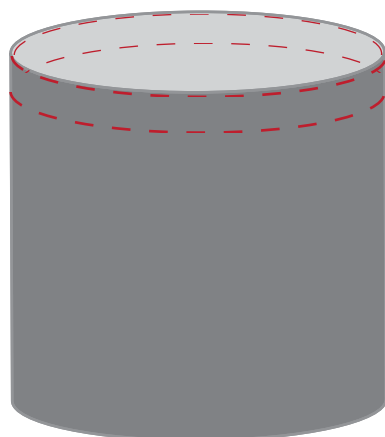

20. You will need to rip the seam open in between the two topstitched lines to create an opening for the drawstring. Before doing that, you will need to sew short lines on the seam at the topstitched lines to prevent it from becoming unsewn.

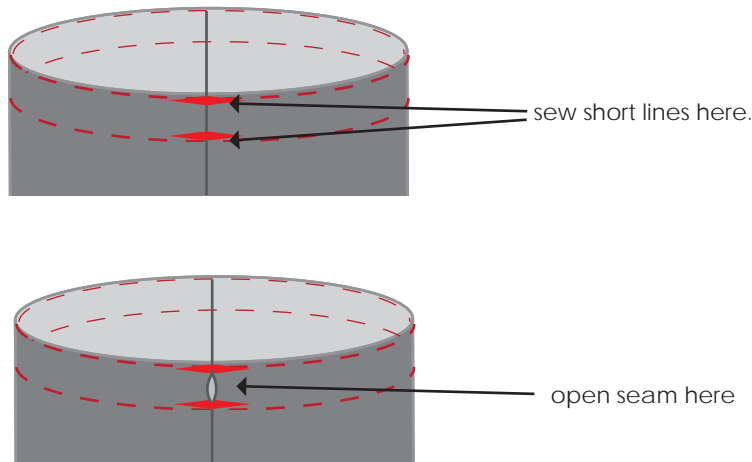

21. Repeat Step 20 with seam on opposite side.

22. At this point, you can sew the opening in the lining shut using a whipstitch or ladder stitch.

## MAKING THE HANDLES

22. Take one Fabric A 22-1/2" x 2-1/2" strip and one 2" x 22" rectangle of batting. Place the batting on the wrong side of the Fabric A piece, making sure that it is centered.

23. Quilt the handles. We quilted two lines spaced about 1/4" along the length of the strips.

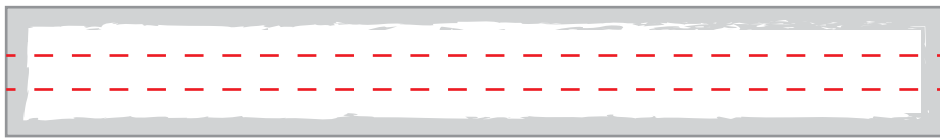

24. Place one Fabric B 22-1/2" x 2-1/2" strip on one of the quilted strips, Right Sides Facing. Stitch around the perimeter with a 1/4" SA, leaving a 2" opening on one side. Trim corners, turn Right Side out and press.

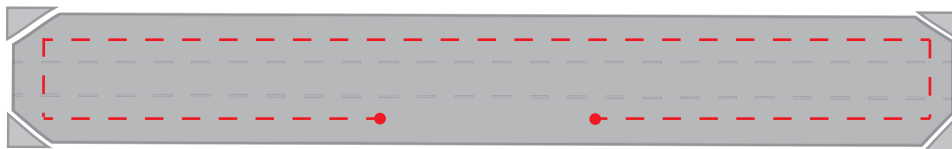

25. Topstitch around the perimeter at 1/8". This will close the opening shut and give your handle a polished look.

Repeat Steps 22-25 to make a second handle.

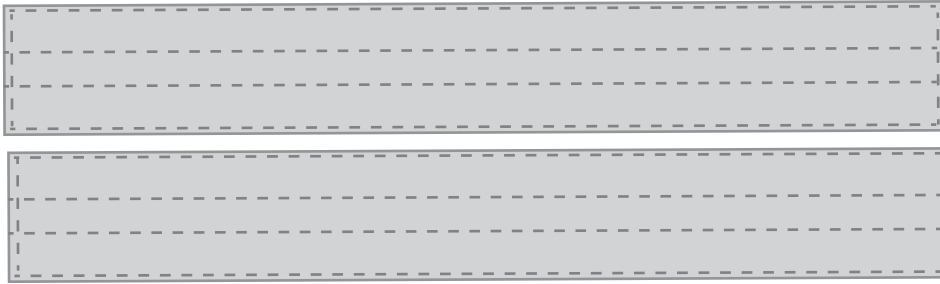

#### MAKING THE DRAWSTRINGS:

26. Take one 45" x 2" Fabric A strip. Fold down 1/4" on each short edge, wrong sides together. Press.



27. Fold in half lengthwise, wrong sides together and press.

28. Unfold, and fold each raw edge into the crease you just created. Press.

29. Fold in half again and press. The image below shows a profile what your strip should look like with all the folds.

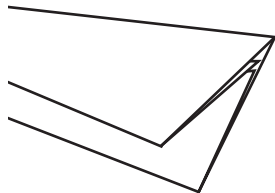

30. Topstitch along the open edge of the strip.



Repeat Steps 26-30 to make a second drawstring.

## FINISHING THE BAG

Sew the handles to the bag.

31. Place one handle on the side of the bag, centered on either side of the seam. Note: each end is positioned 1-1/2" away from the seam and 5" from the top of the bag.

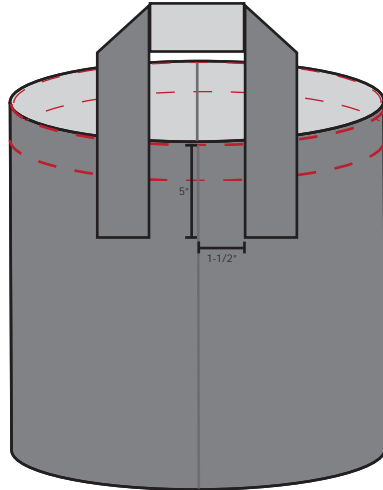

32. Sew the handles to the bag with an 'X' stitch. The 'X' is created with one continuous stitch as shown below. Be sure to take a backstitch at the beginning and end to secure your stitches.

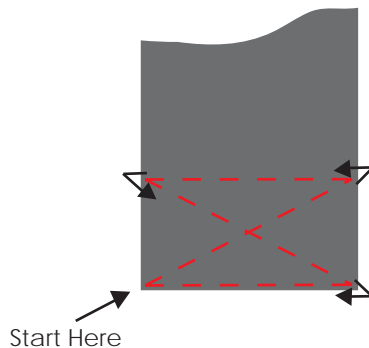

33. Place the large safety pin the end of one of the drawstrings and thread the drawstring through the channel opening created in Step 20. When you come to the opening on the other side, keep threading the drawstring until you get back to where you started. Pull the end out and tie both ends in a knot .

34. Repeat Step 33 with the other drawstring, this time beginning and ending at the opening on the other side.